

TEAMWORK GLOBAL GROUP LIMITED

电机确认书 MOTOR APPROVAL SHEET

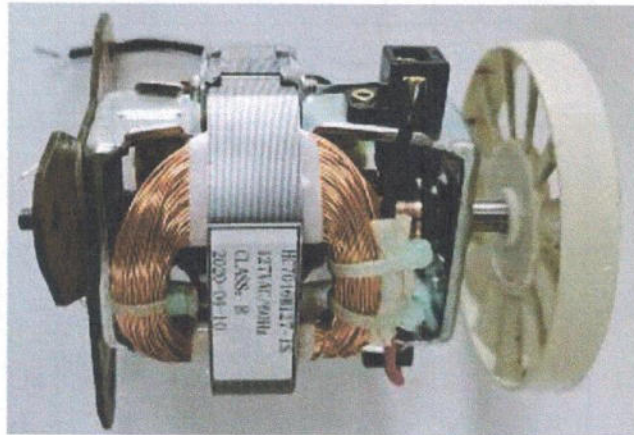

客户物料编号:
CUSTOMER CODE NO :

产品名称:
MACHINE NAME:

搅拌机

产品型号:
MACHINE TYPE:

电机型号:
MOTOR TYPE:

7016M127-B-1S(铜包铝)

电压/频率:
VOLT/FREQ:

127V/AC /60Hz

版本:
VERSION:

A/0

日期:
DATE:

2020.04.09.

制表:
DESIGNED BY:

LIU

审核:
CHECKED
BY:

LONG

批准:
APPROVED BY: LEE

客户确认签名:
CUSTOMER APPROVED SIGNATURES

此为正式生产确认数据, 我方将严格按照此技术数据批量生产

This is formal technical data, all mass order production will be followed exactly according to this approved technical file

1 OF 3 Page

SHENZHEN BAOAN DISTRICT SONGGANG STREET GOLD OPEN 11 EAST MATTERS B24B BUILDING

Tel:0086-0755-85265699

Fax:0086-0755-85266599

电源线: E204893 22AWG 1015# 105°C

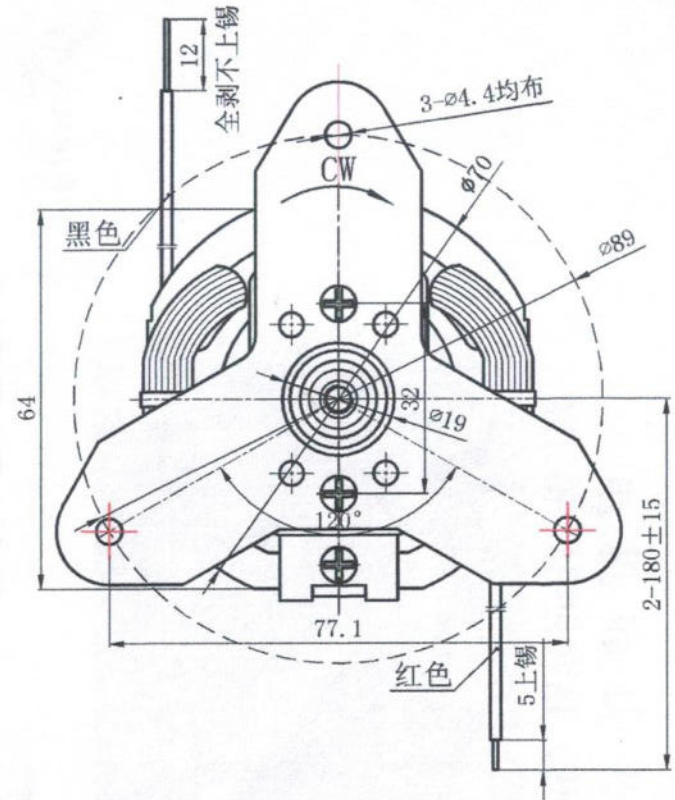
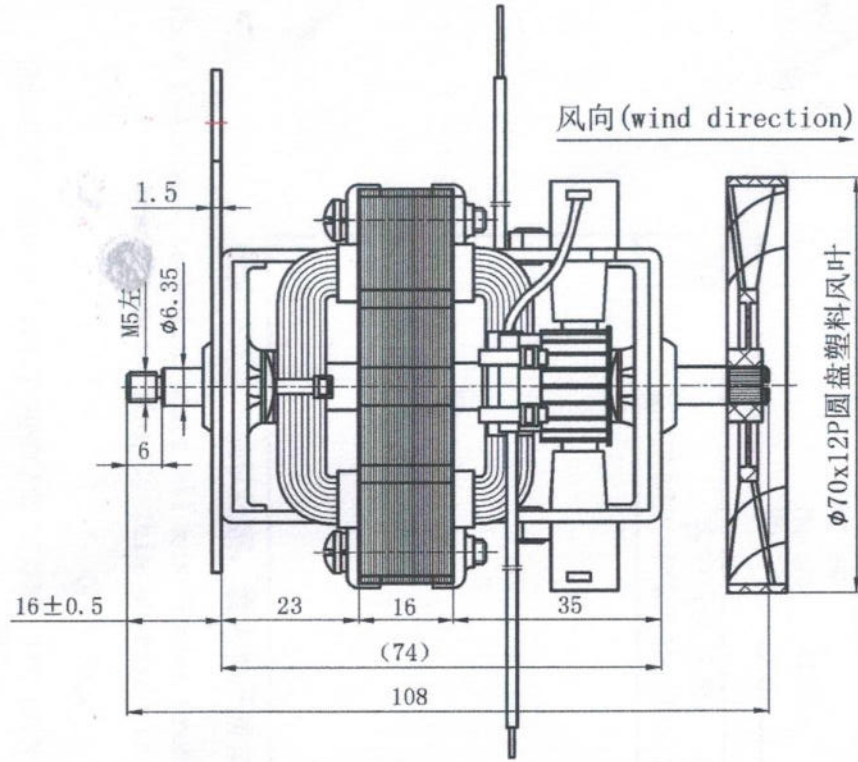

电机外观要求: Motor Appearance requirement:

- 1、电机轴表面光亮、无损伤、无锈迹。
Motor shaft surface brightness, no scratch & rust"
- 2、螺丝紧固、不松动, 松脱扭力 $\geq 5\text{Kgf}\cdot\text{cm}$, 碳套不松动, 安装螺孔标准。
Screw tighten, unfasten torque $\geq 5\text{Kgf}\cdot\text{cm}$; No loosen brush cage."
- 3、引线拉脱力 $\geq 3\text{Kg}$ 。
Leadwire pull-out force $\geq 3\text{Kg}$ "
- 4、尼龙扎带绑扎牢固, 温控器与线圈贴合紧密。
Nylon cable ties fastened, Thermal protector fit tight with winding"
- 5、定子线圈包扎紧固, 浸漆均匀, 无漆瘤。
Stator winding tighted, Insulation varnish evenly distributed."
- 6、电机外观良好, 铁芯无锈斑、伤痕、残缺; 无变形。
Motor Appearance good, no rust, scratch and deformation allowed."
- 7、接地符号标识清楚, 电机印章或铭牌字体工整、清晰。
The Grounding mark clearly, motor label clearly"

标签内容 (label)

7016M127
127VAC/60Hz
CLASS: B
2020-XX-XX

电气原理图
Electrical diagrams

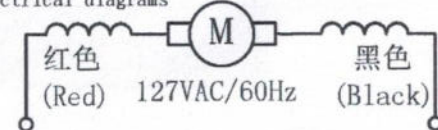

2		一般尺寸公差 X ± 0.2	TEAMWORK GLOBAL GROUP LIMITED	
1		X.X ± 0.1 X.XX ± 0.05 角度 $\pm 20'$ 圆角和倒角0.5	品名: Y16-7016M127-B-铜包铝 搅拌机电机外形图	
CHG 修改	DESCRIPTION 说明	MATERIAL	品号:	
DRAWN 绘制			品号:	
CHECKED 校对		SCALE A1	UNIT mm	
APPROVED 批准		SIZE A4	UNIT mm	
		页次: 3	版本: A/0	

TEAMWORK GLOBAL GROUP LIMITED

SHENZHEN BAOAN DISTRICT SONGGANG STREET GOLD OPEN 11 EAST MATTERS B24B BUILDING

Tel: 0086-0755-85265699

Fax: 0086-0755-85266599

电机性能测试报告 Performance test report

第2页

电机型号 Motor Model:		7016M127-B-1S(铜包铝)		额定电压 / 频率 rated Voltage/Frequency		127VAC 60Hz		项目编号 Item No.					
序号	检测项目 Item		标准 Standard	测试结果 Results									
				1	2	3	4						
1	电气特性 Electric characteristics	空载 Free load	电流 Current	1.55 ± 15% (A)	1.591	1.508	1.565	1.572					
2			功率 Power	195 ± 15% (W)	198	188	195	196					
3			转速 Speed	21500 ± 15% (rpm)	21200	21800	21300	21400					
4			火花 Spark	≤ 1.5 (class)	√	√	√	√					
5		负载 On load	负载风叶 Fan onload	37.5x80 (A4)	√	√	√	√					
6			电流 Current	3.3 ± 10% (A)	3.318	3.299	3.256	3.351					
7			功率 Power	400 ± 10% (W)	403	401	396	407					
8			转速 Speed	11600 ± 10% (rpm)	11700	11500	11500	11600					
9			火花 Spark	≤ 2 (class)	√	√	√	√					
10	机械特性 Machine characteristics	转向 Rotation	CW	√	√	√	√						
11		轴伸 Extension	14.5 ± 0.5 (M5左x6) +1.5	√	√	√	√						
12		虚位 End play	0.5~1.3mm	√	√	√	√						
13		噪音 Noise	≤ 95 (dB-1000mm)	√	√	√	√						
14		振动 Vibration	≤ 20 (mm/s)	√	√	√	√						
15	安全性 Safe	高压测试 Hi-pot test	1800VAC / 2mA / 1SEC	√	√	√	√						
16		绝缘电阻 Insulation resistance	冷态 Cold Conditions ≥ 50 (MΩ) 热态 Hot Conditions ≥ 5 (MΩ)	√	√	√	√						
17		绝缘等级 Insulation Class	B	√	√	√	√						

制表 DESIGNED BY: LIU

审核 CHECKED BY: LONG

批准 APPROVED BY: LEE